

REVISIONS			
REV.	DESCRIPTION	DATE	APPROVED
B	UPDATED DRAWING FOR LEG BRACKET	08/1/18	SF

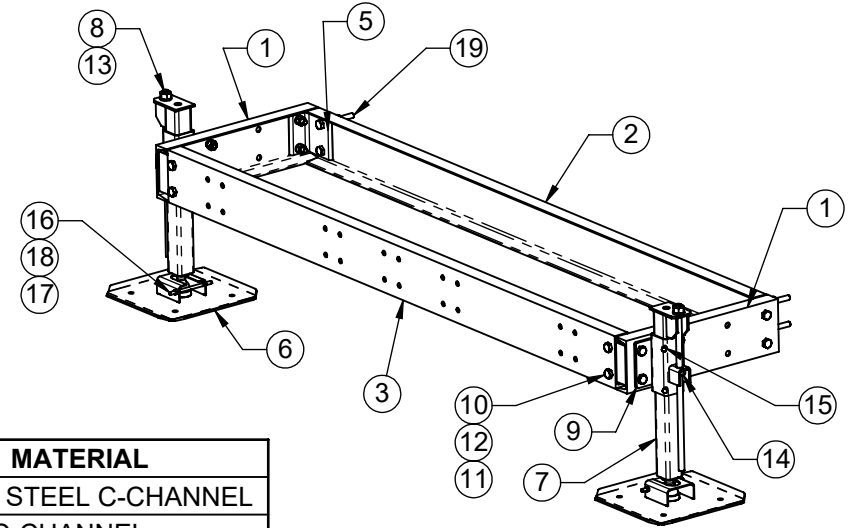

ITEM NO.	QTY.	PART NO.	DESCRIPTION	MATERIAL
1	2	7000-2110J-24EXT-1.1	2' EXT CHANNEL	C7 X 9.8 STEEL C-CHANNEL
2	1	7000-2110J-88-2	MID CHANNEL	C7X9.8 C-CHANNEL
3	1	7000-2110J-88-3	END CHANNEL	C7X9.8 C-CHANNEL
4	1	7000-2110J-G24-96	1" X 1/8" PLATFORM GRATING 24" X 96"	1" X 1/8" STEEL GRATING
5	4	7000-2110J-15.3	C7 CHANNEL BRACKET	3/8" X 5" X 3" STEEL ANGLE
6	2	7000-2110J-JP	JACKPAD WELDMENT (15.5" SQ)	
7	2	7000-2110J-1	INNER JACK SLEEVE WELDMENT	
8	2	7000-2110J-2	3/4" ALL-THREAD/NUT WELDMENT	
9	2	7000-2110J-3	JACK LEG BRACKET	
10	16	4467G-2	BOLT, 5/8" X 2" LG HEX, A325 GALV	
11	20	4660G-BULK	5/8" GALV HEX NUT	
12	20	4764G-BULK	5/8" GALV LOCK WASHER	
13	2	4770G	WASHER, 3/4" NARROW, GALV	
14	2	4670G-BULK	NUT, 3/4" HEX, A563 GALV	
15	4	4423G-BULK	BOLT, 3/8" X 1" LG HEX, GALV	
16	2	4310G-612	3/8" DIA X 6-1/2" LG GALV ALL-THREAD	
17	4	4620G-BULK	NUT, 3/8" HEX, GALV	
18	2	4724G-BULK	3/8" LOCK WASHER, GALV	
19	4	4466G-11-5	BOLT, 5/8" X 5" LG HEX, A325 GALV	
20	6	2199	GRATING CLIP (NOT SHOWN)	

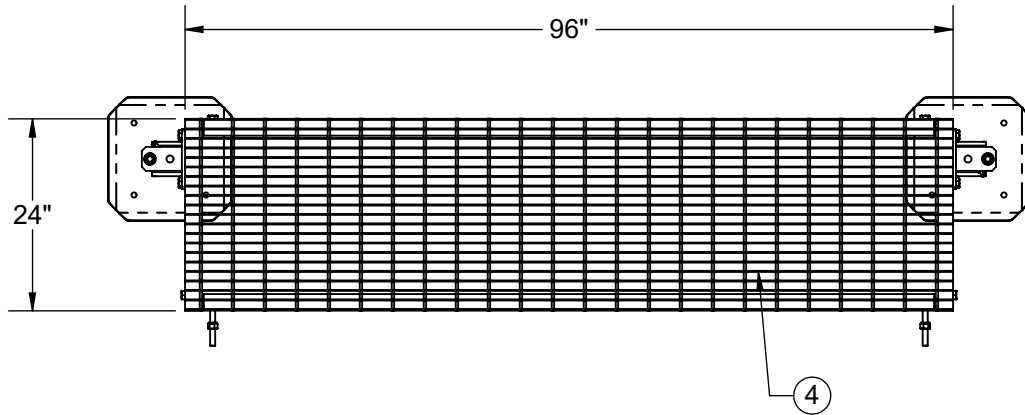

800-950-7960
 FAX 940-455-2817
 www.altfabrication.com
 sales@altfabrication.com

122 Leesley Lane
 Argyle, Texas
 76226

DO NOT SCALE DRAWING UNLESS OTHERWISE SPECIFIED DIMENSIONS ARE IN INCHES. TOLERANCES ARE: FRACTIONS DECIMALS ANGLES $\pm 1/32$.XX $\pm .XX$ $\pm 1^\circ$.XXX $\pm .XXX$ 8/1/2018	MATERIAL PROD# SEE B.O.M.	APPROVALS		DATE
		DRAWN	SF	10/29/16
		CHECKED	DMR	10/29/16
		ENGR.		
		ISSUED		
FINISH HDG		MANUFACT.		

TITLE: 2' X 8' PLATFORM EXTENSION		
SIZE A	DWG. NO. 2110J-88EXT-2	REV. B
SCALE: NTS	WEIGHT 381.60	SHEET 1 OF 1

THE INFORMATION CONTAINED IN THIS DRAWING IS THE SOLE PROPERTY OF ALT. ANY REPRODUCTION IN PART OR WHOLE WITHOUT THE WRITTEN PERMISSION OF ALT IS PROHIBITED.