

SECTION A-A

GRATING REMOVED FOR CLARITY

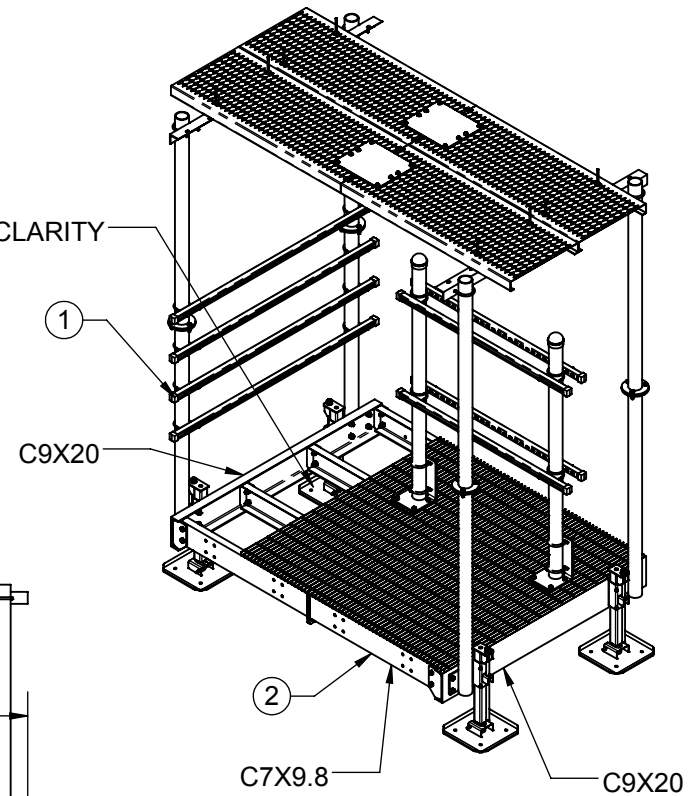

1/2" SPLICE PLATES
(4) Ø 5/8" BOLTS

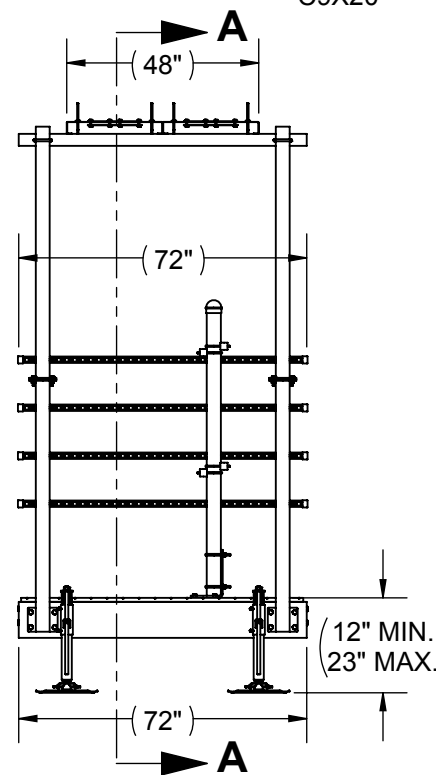
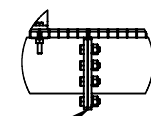

DETAIL B

ITEM NO.	QTY.	PART NO.	DESCRIPTION
1	1	2110JC-68	CANOPY KIT FOR 6' X 8' PLATFORM
2	1	2110J-68HD	6' X 8' HD PLATFORM

THE INFORMATION CONTAINED IN THIS DRAWING IS THE SOLE PROPERTY OF ALT. ANY REPRODUCTION IN PART OR WHOLE WITHOUT THE WRITTEN PERMISSION OF ALT IS PROHIBITED.		CAD GENERATED DRAWING, DO NOT MANUALLY UPDATE		 800-950-7960 FAX 940-455-2817 www.altfabrication.com sales@altfabrication.com		122 Leesley Lane Argyle, Texas 76226	
APPROVALS	DATE	TITLE:					
DRAWN SF	11/29/16	6' X 8' HD PLATFORM WITH ICE CANOPY					
CHECKED DMR	11/29/16	DWG. NO.					
ENGINEER		2110JWIC-68HD					
ISSUED		REV. A					
FINISH: HDG	WEIGHT: 1851.4	SCALE: NTS		DO NOT SCALE DRAWING		SHEET: 1 OF 1	