

1. GRATING AND GRATING CLIPS OMITTED FOR CLARITY
2. LEG LENGTHS ARE ADJUSTED BY TURNING ITEM 8 NUT AFTER ITEM 18 NUT IS INSTALLED
3. INSTALL AND TIGHTEN ITEM 16 SET SCREWS AFTER FINAL LEG ADJUSTMENTS HAVE BEEN MADE.

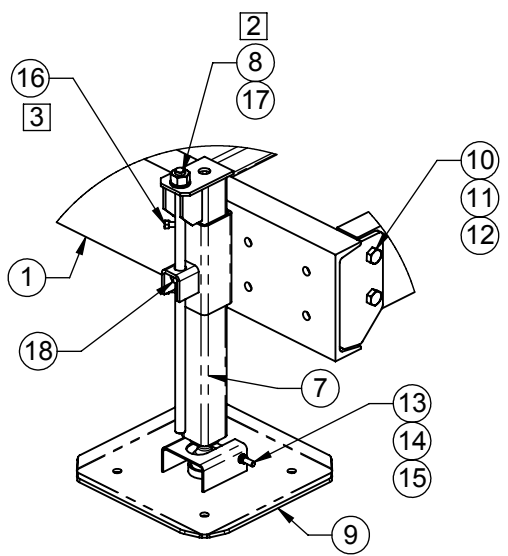

**DETAIL A**

ITEM NO.	QTY.	PART NO.	DESCRIPTION	MATERIAL
1	2	7000-2110J-68HD-1	WELDMENT, SIDE CHANNEL	C9X20
2	2	7000-2110J-68HD-2	MID CHANNEL	C7X9.8
3	2	7000-2110J-68HD-3	MID CHANNEL	C7X9.8
4	2	7000-2110J-68HD-4	END CHANNEL	C7X9.8
5	2	7000-2110J-68HD-5	END CHANNEL	C7X9.8
6	4	7000-2110J-68-4	1" X 1/8" PLATFORM GRATING 24" X 70-1/2"	
7	4	7000-2110J-1	INNER JACK SLEEVE WELDMENT	
8	4	7000-2110J-2	3/4" ALL-THREAD/NUT WELDMENT	
9	4	7000-2110J-JP	JACKPAD WELDMENT (15.5" SQ)	
10	32	4467G	BOLT, 5/8" X 2" LG HEX, A325 GALV	
11	32	4660G-BULK	5/8" GALV HEX NUT	
12	32	4764G-BULK	5/8" GALV LOCK WASHER	
13	4	4310G-612	3/8" DIA X 6-1/2" LG GALV ALL-THREAD	
14	8	4620G-BULK	NUT, 3/8" HEX, GALV	
15	4	4724G-BULK	3/8" LOCK WASHER, GALV	
16	8	4423G-BULK	BOLT, 3/8"X1"LG HEX, GALV	
17	4	4770G	WASHER, 3/4" NARROW, GALV	
18	4	4670G-BULK	NUT, 3/4" HEX, A563 GALV	
19	24	2199	GRATING CLIP (NOT SHOWN)	

THE INFORMATION CONTAINED IN THIS DRAWING IS THE SOLE PROPERTY OF ALT. ANY REPRODUCTION IN PART OR WHOLE WITHOUT THE WRITTEN PERMISSION OF ALT IS PROHIBITED.

11/30/2016

FINISH: HDG WEIGHT: 996

CAD GENERATED DRAWING, DO NOT MANUALLY UPDATE

APPROVALS	DATE
DRAWN SF	11/29/16
CHECKED DMR	11/30/16
ENGINEER	
ISSUED	



800-950-7960  
FAX 940-455-2817  
www.altfabrication.com  
sales@altfabrication.com

122 Leesley Lane  
Argyle, Texas  
76226

TITLE:	6' X 8' HD PLATFORM	
DWG. NO.	2110J-68HD	
SCALE: NTS	DO NOT SCALE DRAWING	SHEET: 1 OF 2
REV.	A	

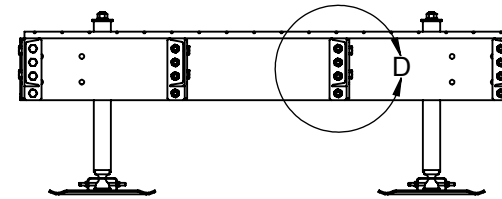
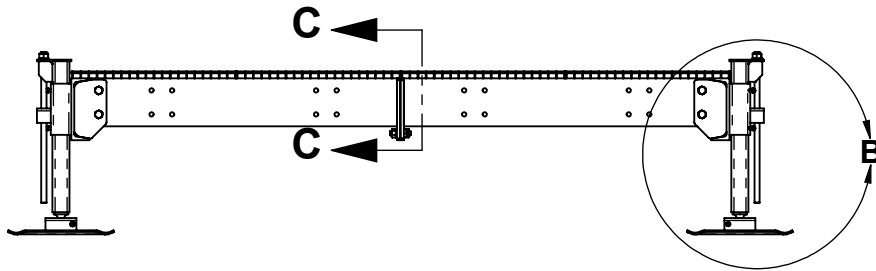
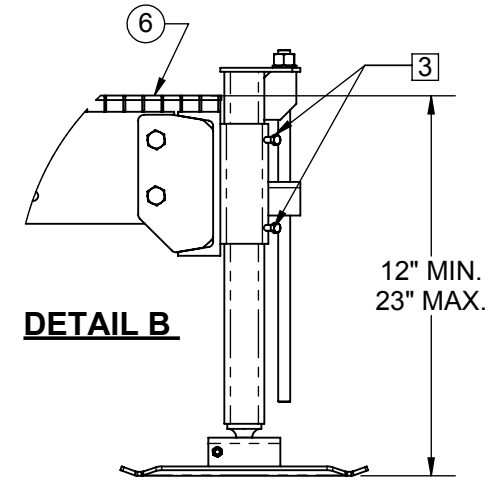
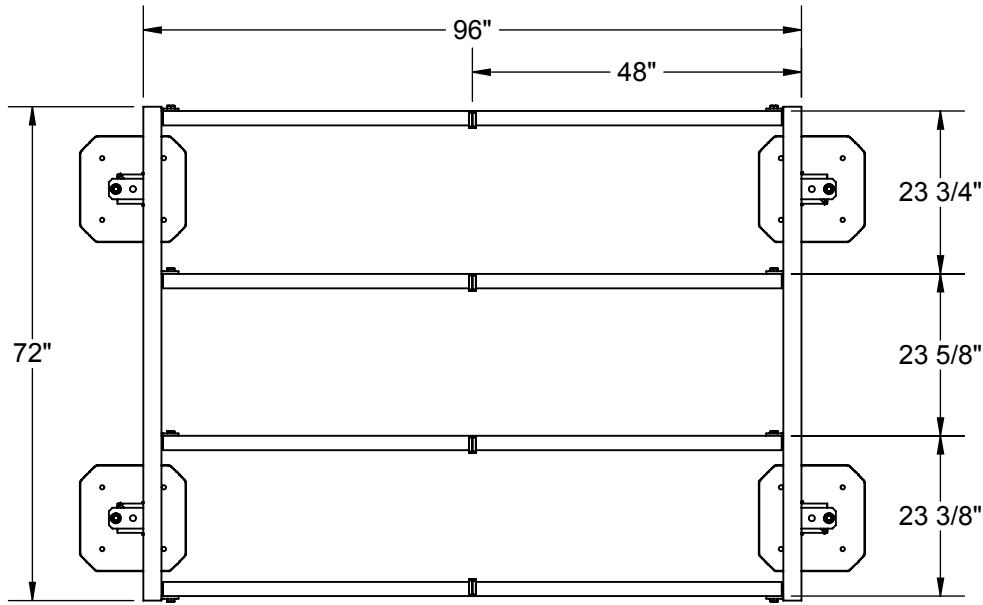

SECTION C-C

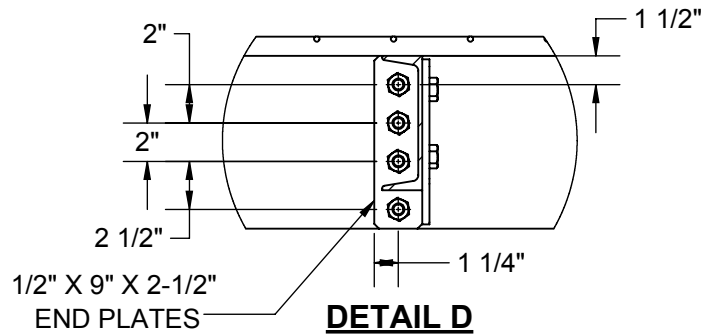

THE INFORMATION CONTAINED IN THIS DRAWING IS THE SOLE PROPERTY OF ALT. ANY REPRODUCTION IN PART OR WHOLE WITHOUT THE WRITTEN PERMISSION OF ALT IS PROHIBITED.  11/30/2016		CAD GENERATED DRAWING, DO NOT MANUALLY UPDATE		 800-950-7960 FAX 940-455-2817 www.altfabrication.com sales@altfabrication.com	122 Leesley Lane Argyle, Texas 76226
		APPROVALS DRAWN SF 11/29/16 CHECKED DMR 11/30/16 ENGINEER	DATE 11/29/16 11/30/16		
FINISH: HDG    WEIGHT: 996		ISSUED		DWG. NO. 2110J-68HD	
		SCALE: NTS    DO NOT SCALE DRAWING		SHEET: 2 OF 2    REV. A	