

**PART NO.**  
2164-XL

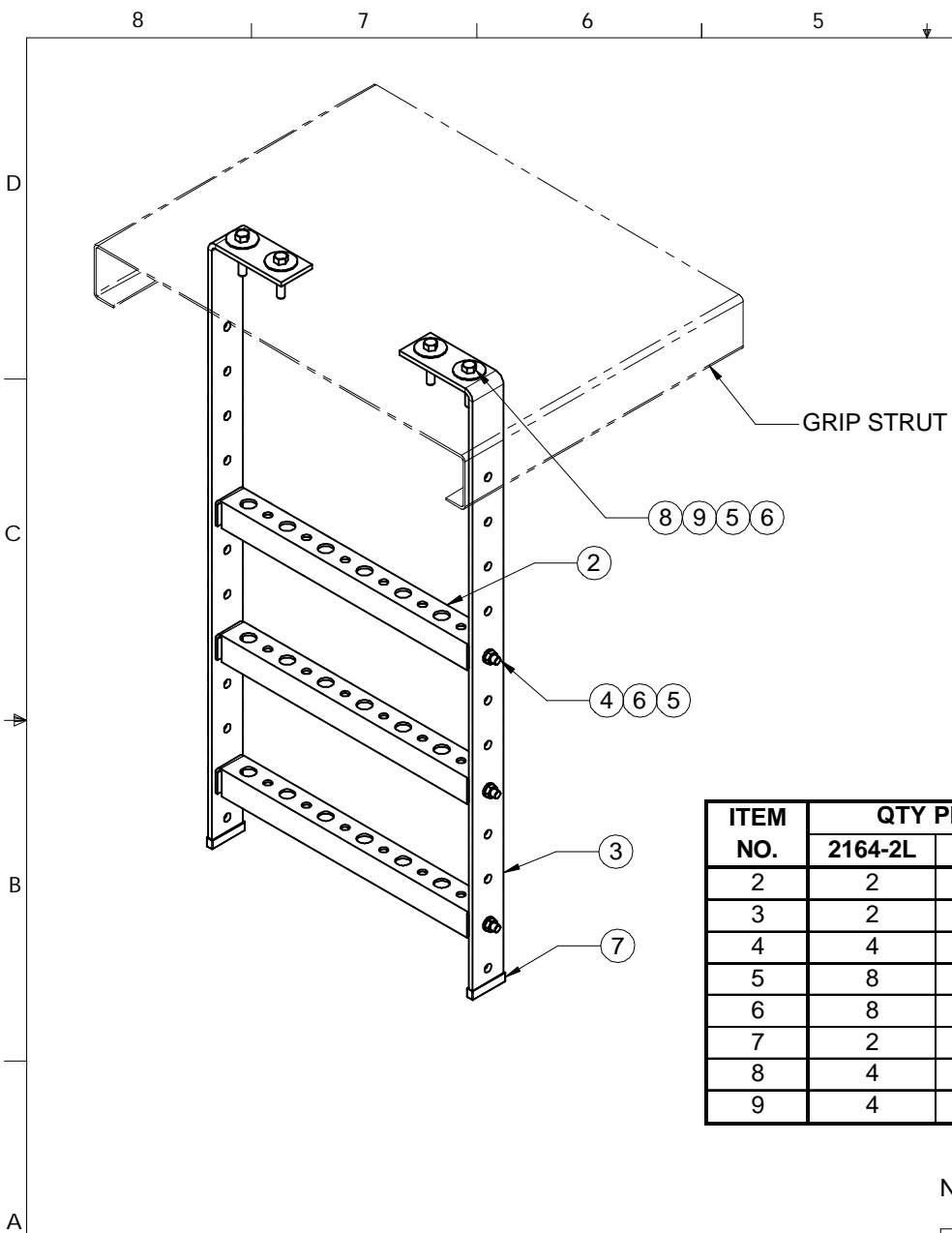

ITEM NO.	QTY PER ASSEMBLY			PART NO.	ITEM DESCRIPTION
	2164-2L	2164-3L	2164-4L		
2	2	3	4	7000-2100.3	6 HOLE LADDER RUNG
3	2	2	2	7000-2164-1	TRAPEZE,VERTICAL HANGER
4	4	6	8	4423G	BOLT, 3/8" X 1" LG HEX, GALV
5	8	10	12	4724G	WASHER, 3/8" RGLR LOCK,GALV
6	8	10	12	4621G	NUT, 3/8" HEX, GALV
7	2	2	2	9062	SAFETY TIP FOR 1/4" X 2" FLATBAR
8	4	4	4	4425G	BOLT, 3/8" X 2" LG HEX, GALV
9	4	4	4	4720FG	WASHER, FENDER, 3/8" GALV

NOTE: 2164-3L INSTALLATION SHOWN, 2164-2L & 2164-4L SIMILAR

<p>THE INFORMATION CONTAINED IN THIS DRAWING IS THE SOLE PROPERTY OF ALT. ANY REPRODUCTION IN PART OR WHOLE WITHOUT THE WRITTEN PERMISSION OF ALT IS PROHIBITED.</p> <p>2/2/2004</p>	<p>CAD GENERATED DRAWING. DO NOT MANUALLY UPDATE</p>		<p>800-950-7933 FAX 940-455-2817 www.altfabrication.com sales@altfabrication.com</p>	<p>122 Leesley Lane Argyle, Texas 76226</p>		
	<p>APPROVALS</p>				<p>DATE</p>	
	<p>DRAWN</p>	<p>CDM</p>	<p>01/31/04</p>	<p><b>TRAPEZE ASSY</b></p>		
	<p>CHECKED</p>	<p>JMD</p>	<p>02/02/04</p>			
	<p>ENGINEER</p>	<p>JMD</p>	<p>02/02/04</p>			<p>DWG. NO.</p>
<p>ISSUED</p>	<p>DMR</p>	<p>02/02/04</p>	<p>2164-XL</p>			<p>A</p>
<p>SCALE: NTS</p>			<p>DO NOT SCALE DRAWING</p>	<p>SHEET 1 OF 1</p>		