

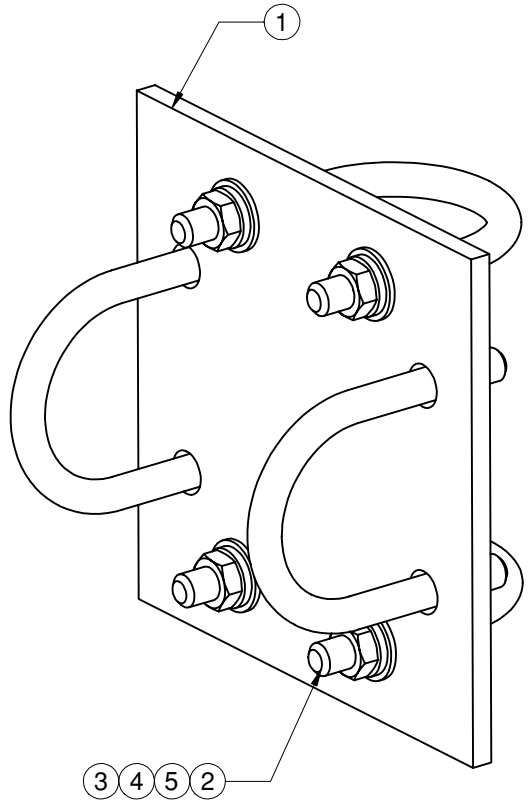

8 7 6 5 4 3 2 1

D
C
B
A



| ITEM NO. | QTY. | PART NO. | DESCRIPTION |
|----------|------|-------------|---|
| 1 | 1 | 7000-2120-4 | CROSSOVER PLATE, 1.9" OD PIPE TO 1.9" OD PIPE |
| 2 | 4 | 4477G | U-BOLT, 1-1/2" (1.90" OD) PIPE, GALV (3/8" DIA) |
| 3 | 8 | 4720G | WASHER, 3/8" NARROW, GALV |
| 4 | 8 | 4724G | WASHER, 3/8" RGLR LOCK, GALV |
| 5 | 8 | 4621G | NUT, 3/8" HEX, GALV |

| | | | | | | |
|---|--|-----------------|--|--|-------------|--------------------------------------|
| <p>THE INFORMATION CONTAINED IN THIS DRAWING IS THE SOLE PROPERTY OF ALT. ANY REPRODUCTION IN PART OR WHOLE WITHOUT THE WRITTEN PERMISSION OF ALT IS PROHIBITED.</p> <p>3/26/2002</p> | <p>CAD GENERATED DRAWING, DO NOT MANUALLY UPDATE</p> | |  <p>800-950-7933 FAX 940-455-2817 www.advancedlightning.com sales@advancedlightning.com</p> | <p>122 Leesley Lane Argyle, Texas 76226</p> | | |
| | <p>APPROVALS</p> | | | | <p>DATE</p> | |
| | <p>DRAWN</p> | <p>JMD</p> | <p>01/22/02</p> | <p>CROSS-OVER PLATE ASSY 1.9" TO 1.9" OD</p> | | |
| | <p>CHECKED</p> | <p>MAD</p> | <p>01/30/02</p> | | | |
| | <p>ENGINEER</p> | <p>JMD</p> | <p>01/30/02</p> | | | <p>DWG. NO.</p> <p>2120-4</p> |
| <p>ISSUED</p> | <p>DMR</p> | <p>03/11/02</p> | <p>SCALE: NTS</p> | | | <p>DO NOT SCALE DRAWING</p> |