

8

7

6

5

4

3

2

1

PART NO.

2120-10

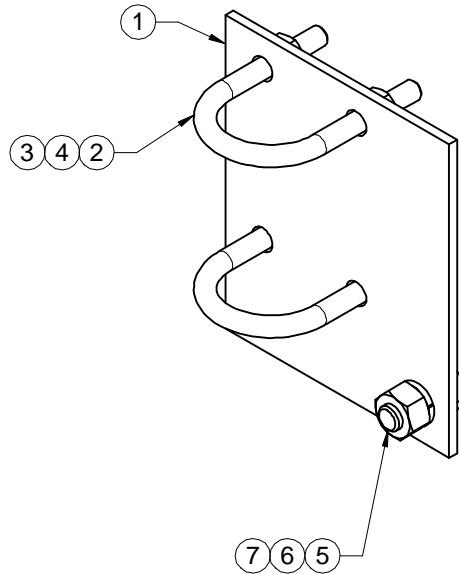

ITEM NO.	QTY.	PART NO.	DESCRIPTION
1	1	7000-2120-10.1	MOUNT PLATE, SWAY BAR
2	2	4499-4G	U-BOLT, 2" (2.38" OD) PIPE, GALV (1/2" DIA)
3	4	4650G	NUT, 1/2" HEX, A563 GALV
4	4	4754G	WASHER, 1/2" RGLR LOCK, GALV
5	1	4467G-112	BOLT, 5/8" X 1-1/2" LG HEX, A325 GALV
6	1	4660G	NUT, 5/8" HEX, A563 GALV
7	1	4764G	WASHER, 5/8" RGLR LOCK, GALV

THE INFORMATION CONTAINED
IN THIS DRAWING IS THE SOLE
PROPERTY OF ADVANCED
LIGHTNING TECHNOLOGY. ANY
REPRODUCTION IN PART OR
WHOLE WITHOUT THE WRITTEN
PERMISSION OF ADVANCED
LIGHTNING TECHNOLOGY IS
PROHIBITED.

9/12/2003

CAD GENERATED DRAWING.
DO NOT MANUALLY UPDATE

APPROVALS		DATE
DRAWN	CDM	07/06/01
CHECKED	JMD	07/23/01
ENGINEER	JMD	07/23/01
ISSUED	DMR	07/24/01

ADVANCED LIGHTNING TECHNOLOGY

SWAY BAR MOUNT ASSEMBLY

DWG. NO.

2120-10

REV.

A

SCALE: NTS

DO NOT SCALE DRAWING

SHEET 1 OF 1

D

C

B

A