

1. GRATING AND GRATING CLIPS OMITTED FOR CLARITY

2 LEG LENGTHS ARE ADJUSTED BY TURNING ITEM 4 NUT AFTER ITEM 6 NUT IS INSTALLED

3 INSTALL AND TIGHTEN ITEM 15 SET SCREWS AFTER FINAL LEG ADJUSTMENTS HAVE BEEN MADE.

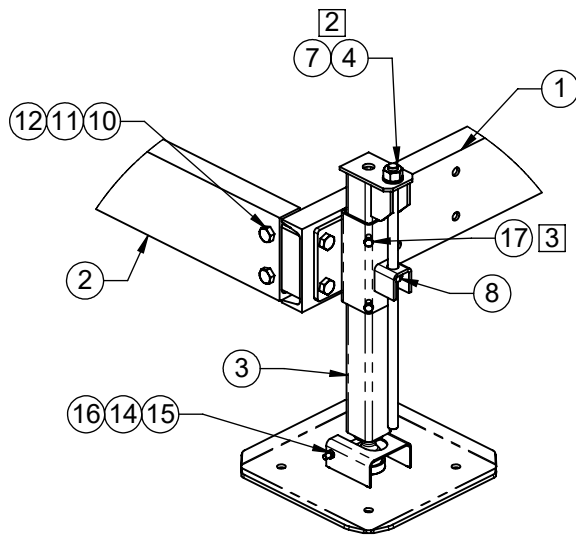

DETAIL A

ITEM NO.	QTY.	PART NO.	DESCRIPTION
1	2	7000-2110J-10.1	C7 SIDE CHANNEL
2	5	7000-2110J-10.8	7000-2110J-10.8
3	6	7000-2110J-1	INNER JACK SLEEVE WELDMENT
4	6	7000-2110J-2	3/4" ALL-THREAD/NUT WELDMENT
5	6	7000-2110J-3	JACK LEG BRACKET
6	10	7000-2110J-15.3	C7 CHANNEL BRACKET
7	4	4770G	WASHER, 3/4" NARROW, GALV
8	4	4670G-BULK	NUT, 3/4" HEX, A563 GALV
9	60	2199	GRATING CLIP (NOT SHOWN)
10	52	4467G-2	BOLT, 5/8" X 2" LG HEX, A325 GALV
11	52	4764G-BULK	5/8" GALV LOCK WASHER
12	52	4660G-BULK	5/8" GALV HEX NUT
13	6	7000-2110J-JP	JACKPAD WELDMENT (15.5" SQ)
14	6	4310G-612	3/8" DIA X 6-1/2" LG GALV ALL-THREAD
15	12	4620G-BULK	NUT, 3/8" HEX, GALV
16	6	4724G-BULK	3/8" LOCK WASHER, GALV
17	12	4423G-BULK	BOLT, 3/8" X 1" LG HEX, GALV
18	4	7000-2110J-G24-120	1" X 1/8" PLATFORM GRATING 24" X 120"

THE INFORMATION CONTAINED IN THIS DRAWING IS THE SOLE PROPERTY OF ALT. ANY REPRODUCTION IN PART OR WHOLE WITHOUT THE WRITTEN PERMISSION OF ALT IS PROHIBITED.

7/26/2018

FINISH: HDG WEIGHT: 1256

CAD GENERATED DRAWING, DO NOT MANUALLY UPDATE

APPROVALS	DATE
DRAWN SF	02/24/15
CHECKED	
ENGINEER	
ISSUED	



800-950-7960
FAX 940-455-2817
www.altfabrication.com
sales@altfabrication.com

122 Leesley Lane
Argyle, Texas
76226

TITLE: PLATFORM 8' X 10'	REV. B
DWG. NO. 2110J-810	SHEET: 1 OF 2
SCALE: NTS	DO NOT SCALE DRAWING

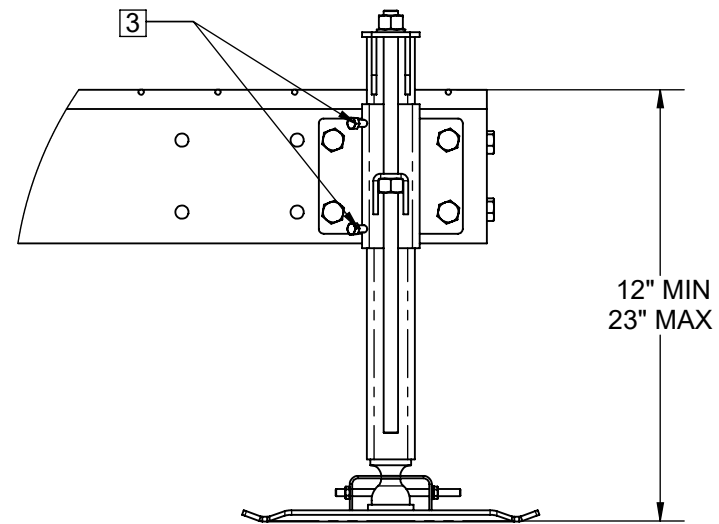
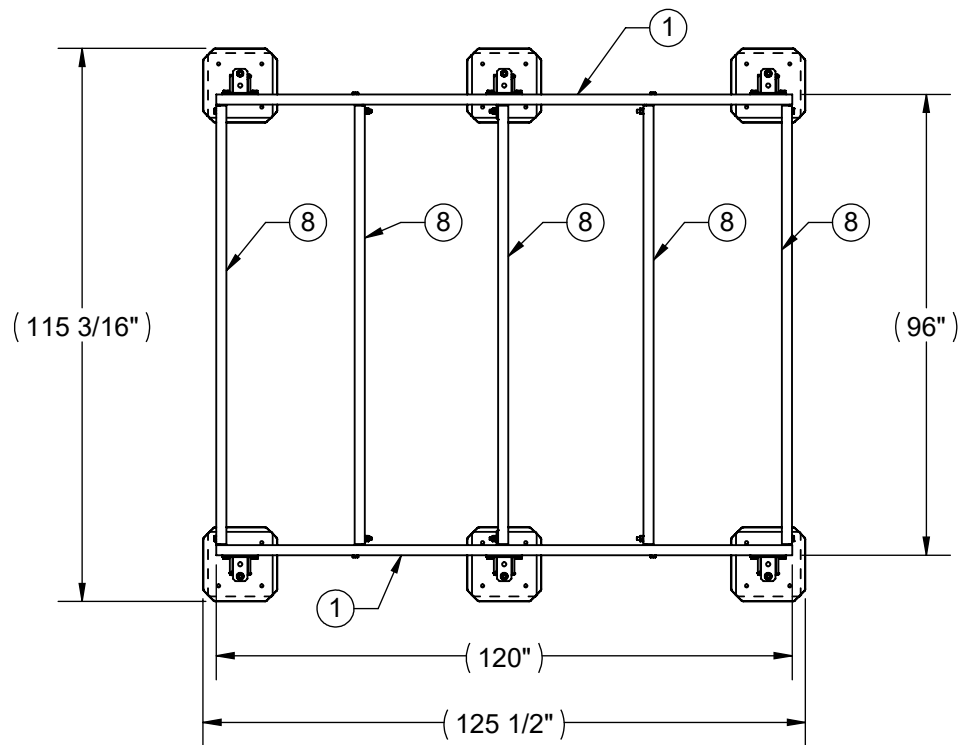

DETAIL C

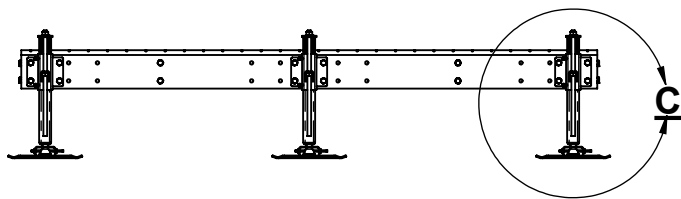

<p>THE INFORMATION CONTAINED IN THIS DRAWING IS THE SOLE PROPERTY OF ALT. ANY REPRODUCTION IN PART OR WHOLE WITHOUT THE WRITTEN PERMISSION OF ALT IS PROHIBITED.</p> <p>7/26/2018</p>	CAD GENERATED DRAWING, DO NOT MANUALLY UPDATE		 <p>800-950-7960 FAX 940-455-2817 www.altfabrication.com sales@altfabrication.com</p>	<p>122 Leesley Lane Argyle, Texas 76226</p>	
	APPROVALS	DATE			TITLE:
	DRAWN	SF	02/24/15	PLATFORM 8' X 10'	
	CHECKED			DWG. NO. 2110J-810	
	ENGINEER			SCALE: NTS	DO NOT SCALE DRAWING
ISSUED			SHEET: 2 OF 2	REV. B	
FINISH: HDG	WEIGHT: 1457.4				