

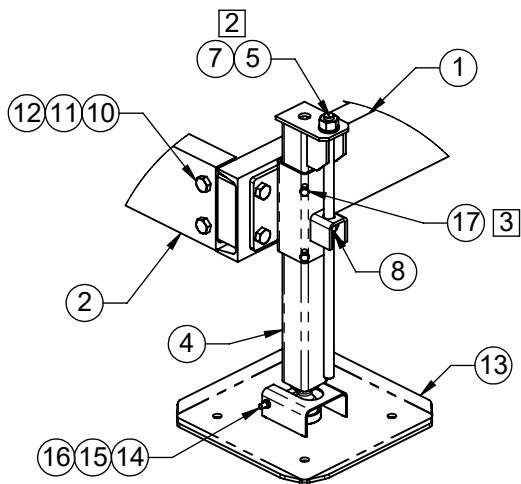

1. GRATING AND GRATING CLIPS OMITTED FOR CLARITY.
2. LEG LENGTHS ARE ADJUSTED BY TURNING ITEM 5 NUT WELDMENT AFTER ITEM 8 NUT IS INSTALLED.
3. INSTALL AND TIGHTEN ITEM 17 SET SCREWS AFTER FINAL LEG ADJUSTMENTS HAVE BEEN MADE.



DETAIL A

| ITEM NO. | QTY. | PART NO. | DESCRIPTION |
|----------|------|-------------------|--------------------------------------|
| 1 | 2 | 7000-2110J-4.1 | CHANNEL, SIDE, (C7X9.8X48"LG) |
| 2 | 3 | 7000-2110J-10.4 | C7X9.8 C-CHANNEL (43-5/16" LG) |
| 3 | 6 | 7000-2110J-15.3 | C7 CHANNEL BRACKET |
| 4 | 4 | 7000-2110J-1 | INNER JACK SLEEVE WELDMENT |
| 5 | 4 | 7000-2110J-2 | 3/4" ALL-THREAD/NUT WELDMENT |
| 6 | 4 | 7000-2110J-3 | JACK LEG BRACKET |
| 7 | 4 | 4770G | WASHER, 3/4" NARROW, GALV |
| 8 | 4 | 4670G-BULK | NUT, 3/4" HEX, A563 GALV |
| 9 | 16 | 2199 | GRATING CLIP (NOT SHOWN) |
| 10 | 32 | 4467G-2 | BOLT, 5/8" X 2" LG HEX, A325 GALV |
| 11 | 32 | 4764G-BULK | 5/8" GALV LOCK WASHER |
| 12 | 32 | 4660G-BULK | 5/8" GALV HEX NUT |
| 13 | 4 | 7000-2110J-JP | JACKPAD WELDMENT (15.5" SQ) |
| 14 | 4 | 4310G-612 | 3/8" DIA X 6-1/2" LG GALV ALL-THREAD |
| 15 | 8 | 4620G-BULK | NUT, 3/8" HEX, GALV |
| 16 | 4 | 4724G-BULK | 3/8" LOCK WASHER, GALV |
| 17 | 8 | 4423G-BULK | BOLT, 3/8"X1"LG HEX, GALV |
| 18 | 2 | 7000-2110J-G24-48 | PLATFORM GRATING 24" X 48" |

| | | | | | |
|---------------------------------------------------------------------------------------------------------------------------------------------------------------|--|-----------------------------------------------|----------|------------------------------------------------------------------------------------------------------------------------------------------------------------------------------|--------------------------------------------|
| THE INFORMATION CONTAINED IN THIS DRAWING IS THE SOLE PROPERTY OF ALT. ANY REPRODUCTION IN PART OR WHOLE WITHOUT THE WRITTEN PERMISSION OF ALT IS PROHIBITED. | | CAD GENERATED DRAWING, DO NOT MANUALLY UPDATE | |  800-950-7960 FAX 940-455-2817 www.altfabrication.com sales@altfabrication.com | 122 Leesley Lane Argyle, Texas 76226 |
| | | APPROVALS | DATE | | |
| 7/31/2018 | | DRAWN SF | 01/03/14 | PLATFORM 4' X 4' | REV. B |
| FINISH: HDG | | CHECKED | ENGINEER | DWG. NO. 2110J-44 | |
| WEIGHT: 398.44 | | ISSUED | | SCALE: NTS DO NOT SCALE DRAWING SHEET: 1 OF 3 | |

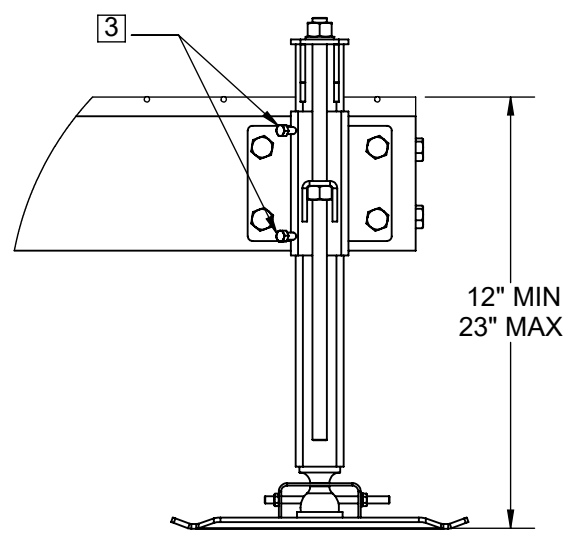
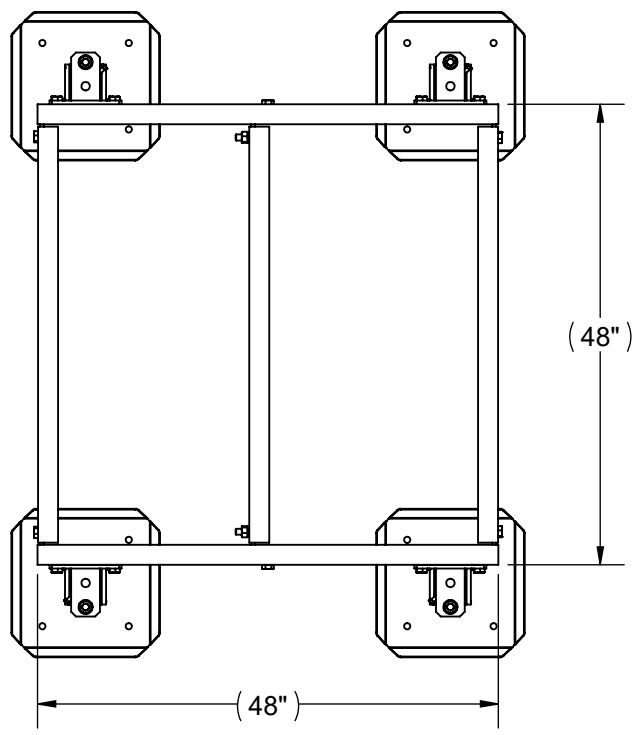

DETAIL B

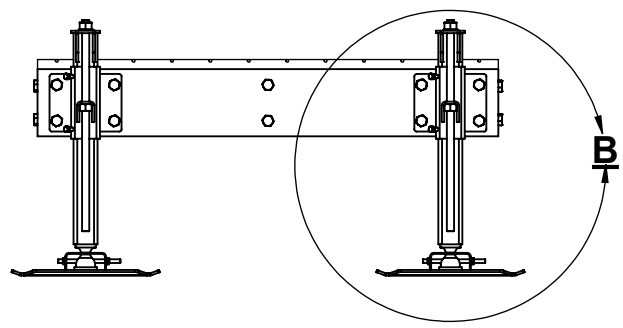

| | | | | | |
|---------------------------------------------------------------------------------------------------------------------------------------------------------------------------------------|----------------------------------------------------------------------------------------------------------------------------------------------------------------------------------------|-----------------------------------------------------|-------------------------------------------|---------------|---------------|
| <p>THE INFORMATION CONTAINED IN THIS DRAWING IS THE SOLE PROPERTY OF ALT. ANY REPRODUCTION IN PART OR WHOLE WITHOUT THE WRITTEN PERMISSION OF ALT IS PROHIBITED.</p> <p>7/31/2018</p> |  <p>800-950-7960 FAX 940-455-2817 www.altfabrication.com sales@altfabrication.com</p> | <p>122 Leesley Lane Argyle, Texas 76226</p> | TITLE: | | |
| | | | <p>PLATFORM 4' X 4'</p> | | |
| FINISH: HDG | WEIGHT: 398.44 | SCALE: NTS | DO NOT SCALE DRAWING | SHEET: 2 OF 3 | REV. B |

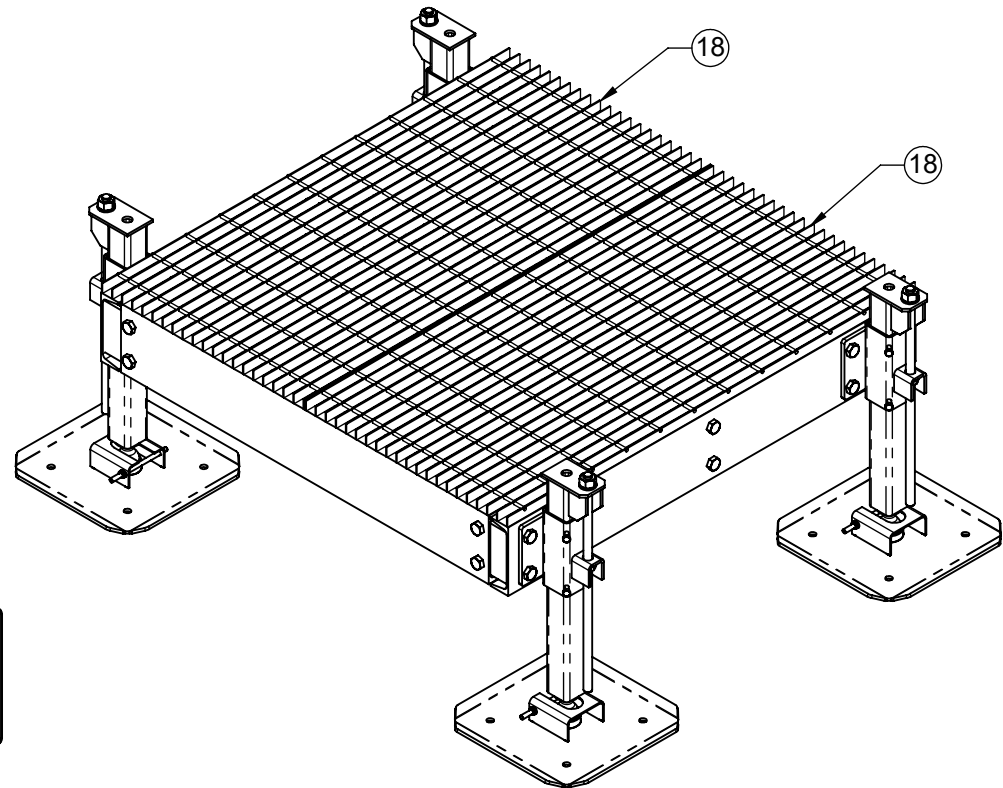
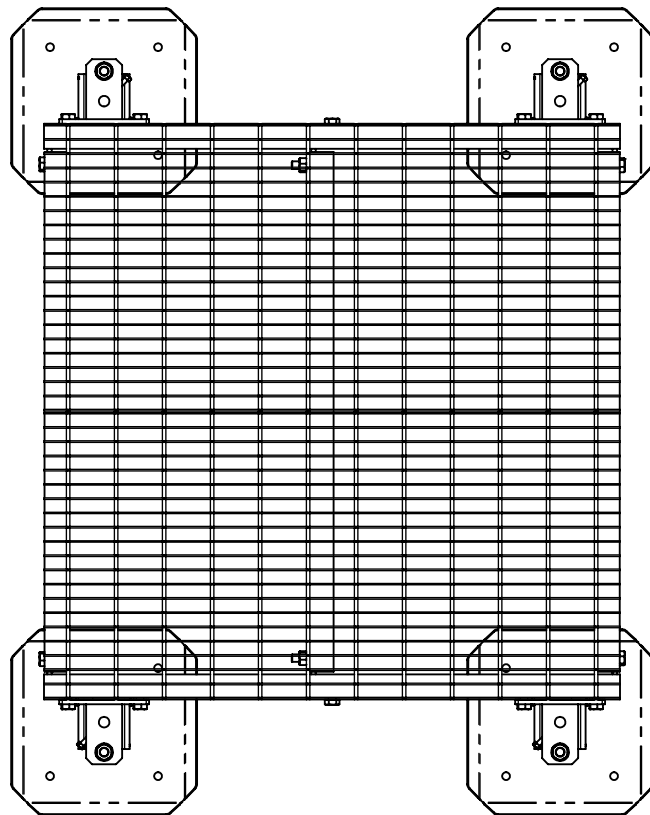

| | | | | | |
|---------------------------------------------------------------------------------------------------------------------------------------------------------------------------------------|----------------------------------------------------------------------------------------------------------------------------------------------------------------------------------------|-----------------------------------------------------|-----------------------------------------------|----------------------|--------------------------|
| <p>THE INFORMATION CONTAINED IN THIS DRAWING IS THE SOLE PROPERTY OF ALT. ANY REPRODUCTION IN PART OR WHOLE WITHOUT THE WRITTEN PERMISSION OF ALT IS PROHIBITED.</p> <p>7/31/2018</p> |  <p>800-950-7960 FAX 940-455-2817 www.altfabrication.com sales@altfabrication.com</p> | <p>122 Leesley Lane Argyle, Texas 76226</p> | | | |
| | | | <p>TITLE: PLATFORM 4' X 4'</p> | | |
| <p>FINISH: HDG</p> | <p>WEIGHT: 398.44</p> | <p>SCALE: NTS</p> | <p>DO NOT SCALE DRAWING</p> | <p>SHEET: 3 OF 3</p> | <p>REV. B</p> |