

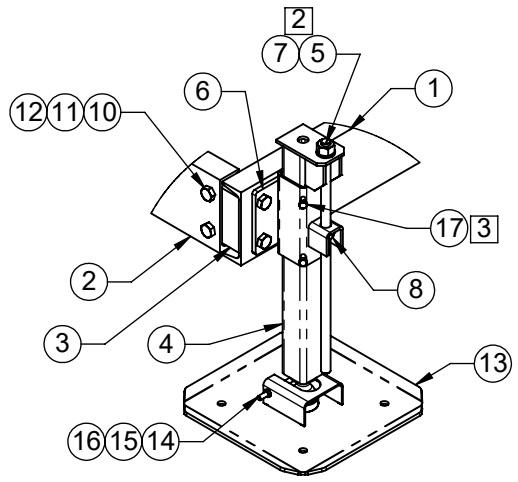

- 1. GRATING AND GRATING CLIPS OMITTED FOR CLARITY
- 2 LEG LENGTHS ARE ADJUSTED BY TURNING ITEM 5 NUT WELDMENT AFTER ITEM 8 NUT IS INSTALLED
- 3 INSTALL AND TIGHTEN ITEM 17 SET SCREWS AFTER FINAL LEG ADJUSTMENTS HAVE BEEN MADE.



DETAIL A

ITEM NO.	QTY.	PART NO.	DESCRIPTION
1	2	7000-2110J-14.1	14' C7 SIDE CHANNEL
2	6	7000-2110J-10.4	C7X9.8 C-CHANNEL (43-5/16" LG)
3	12	7000-2110J-15.3	C7 CHANNEL BRACKET
4	6	7000-2110J-1	INNER JACK SLEEVE WELDMENT
5	6	7000-2110J-2	3/4" ALL-THREAD/NUT WELDMENT
6	6	7000-2110J-3	JACK LEG BRACKET
7	6	4770G	WASHER, 3/4" NARROW, GALV
8	6	4670G-BULK	NUT, 3/4" HEX, A563 GALV
9	16	2199	GRATING CLIP (NOT SHOWN)
10	64	4467G-2	5/8" X 2" A325 GALV. HEX BOLT
11	64	4764G-BULK	5/8" GALV LOCK WASHER
12	64	4660G-BULK	5/8" GALV HEX NUT
13	6	7000-2110J-JP	JACKPAD WELDMENT (15.5" SQ)
14	6	4310G-612	3/8" DIA X 6-1/2" LG GALV ALL-THREAD
15	12	4620G-BULK	NUT, 3/8" HEX, GALV
16	6	4724G-BULK	3/8" LOCK WASHER, GALV
17	12	4423G-BULK	BOLT, 3/8"X1"LG HEX, GALV
18	2	7000-2110J-G24-14	1" X 1/8" PLATFORM GRATING 2' X 168"

THE INFORMATION CONTAINED IN THIS DRAWING IS THE SOLE PROPERTY OF ALT. ANY REPRODUCTION IN PART OR WHOLE WITHOUT THE WRITTEN PERMISSION OF ALT IS PROHIBITED.		CAD GENERATED DRAWING, DO NOT MANUALLY UPDATE		 800-950-7960 FAX 940-455-2817 www.altfabrication.com sales@altfabrication.com		122 Leesley Lane Argyle, Texas 76226	
APPROVALS		DATE		TITLE:			
DRAWN SF		05/09/11		4' X 14' JACK PLATFORM			
CHECKED TU		05/10/11		DWG. NO.			
ENGINEER				2110J-414			
ISSUED				REV. B			
7/30/2018				SCALE: NTS			
FINISH: HDG		WEIGHT: 1109.43		DO NOT SCALE DRAWING SHEET: 1 OF 3			

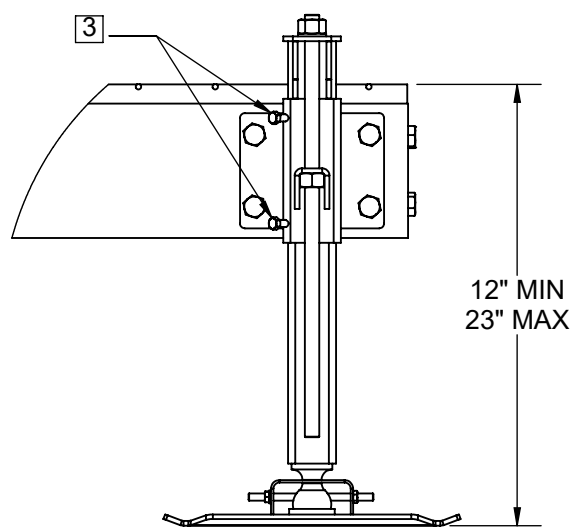
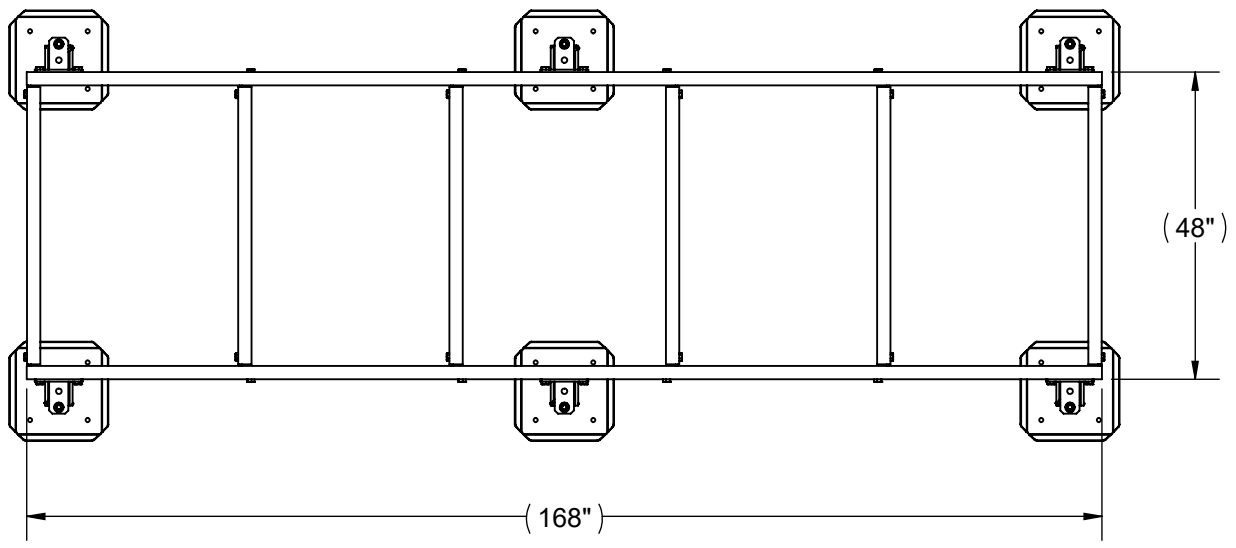

DETAIL B

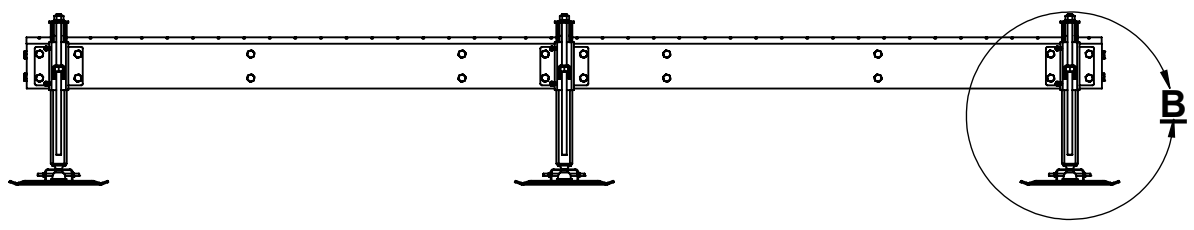

THE INFORMATION CONTAINED IN THIS DRAWING IS THE SOLE PROPERTY OF ALT. ANY REPRODUCTION IN PART OR WHOLE WITHOUT THE WRITTEN PERMISSION OF ALT IS PROHIBITED.

7/30/2018



800-950-7960
FAX 940-455-2817
www.altfabrication.com
sales@altfabrication.com

122 Leesley Lane
Argyle, Texas
76226

TITLE:
4' X 14' JACK PLATFORM

DWG. NO.
2110J-414

REV.
B

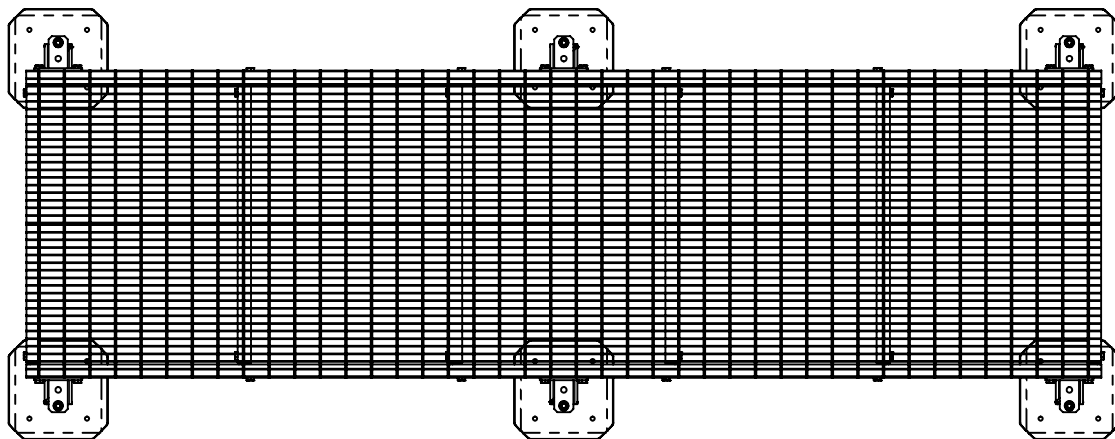
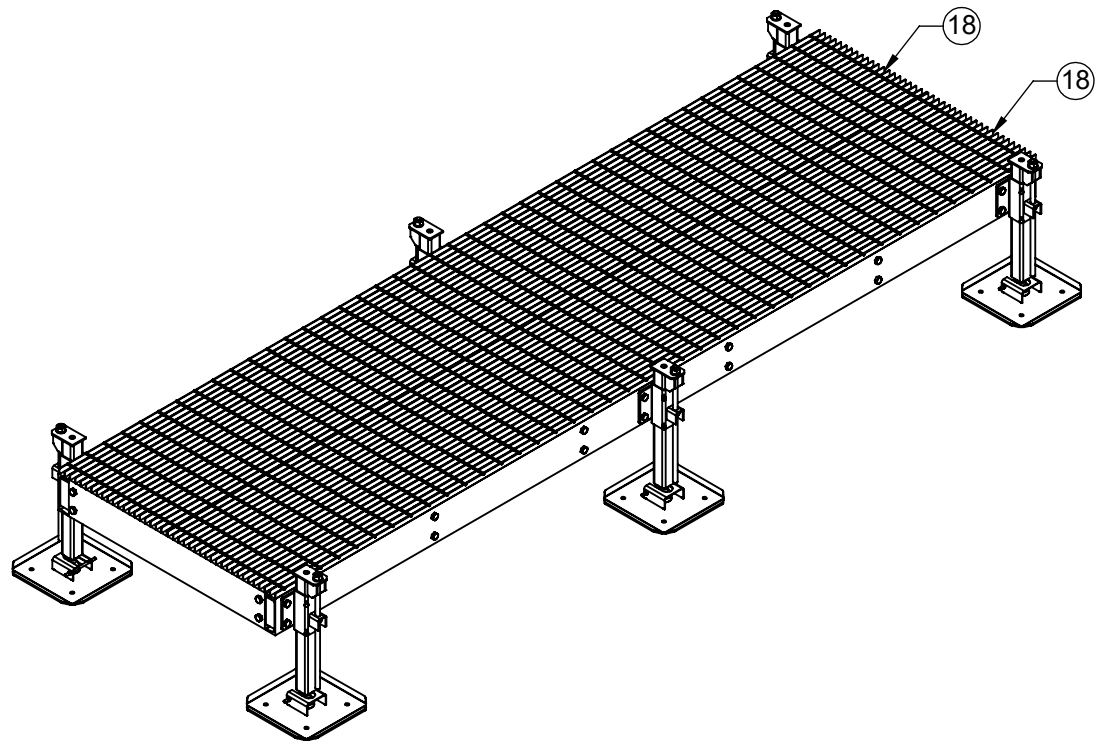

THE INFORMATION CONTAINED
IN THIS DRAWING IS THE SOLE
PROPERTY OF ALT. ANY
REPRODUCTION IN PART OR
WHOLE WITHOUT THE WRITTEN
PERMISSION OF ALT IS
PROHIBITED.

7/30/2018



800-950-7960
FAX 940-455-2817
www.altfabrication.com
sales@altfabrication.com

122 Leesley Lane
Argyle, Texas
76226

TITLE:
4' X 14' JACK PLATFORM

DWG. NO.
2110J-414

REV.
B

FINISH: HDG

WEIGHT: 1109.43

SCALE: NTS

DO NOT SCALE DRAWING

SHEET: 3 OF 3