

REVISIONS			
REV.	DESCRIPTION	DATE	APPROVED
B	DRAWING UPDATED FOR LEG BRACKETS	07/31/18	SF

PART NO. 2110J-1015

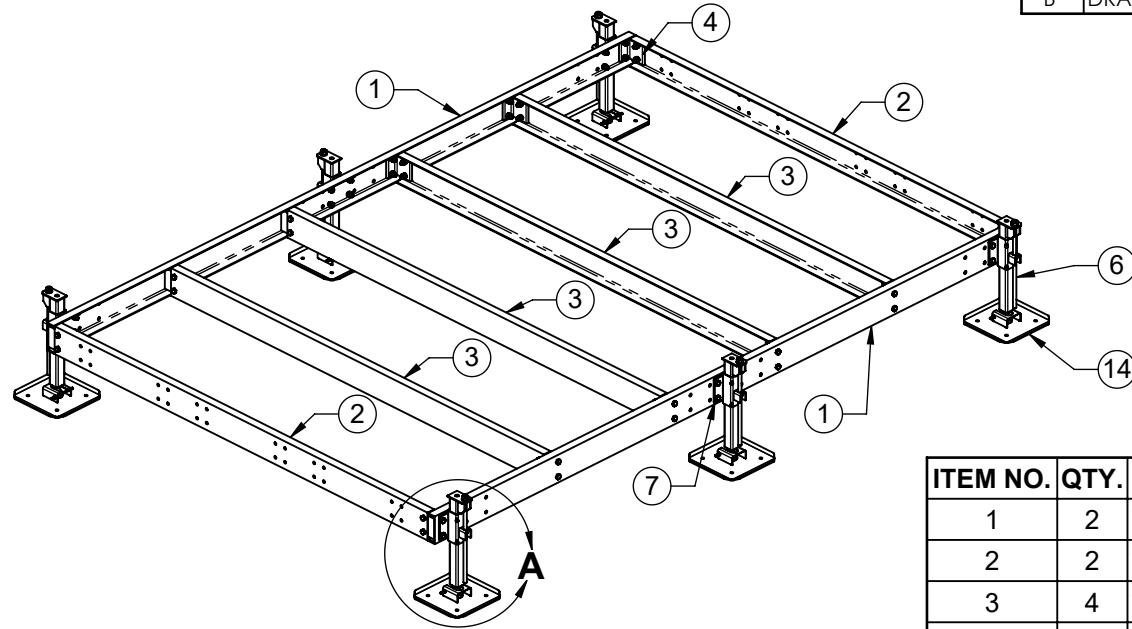

1. GRATING AND GRATING CLIPS OMITTED FOR CLARITY
- 2 LEG LENGTHS ARE ADJUSTED BY TURNING ITEM 6 NUT AFTER ITEM 9 NUT IS INSTALLED
- 3 INSTALL AND TIGHTEN ITEM 18 SET SCREWS AFTER FINAL LEG ADJUSTMENTS HAVE BEEN MADE.

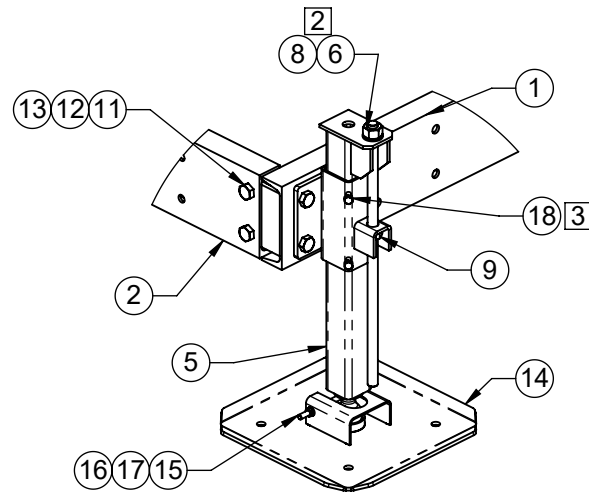

**DETAIL A**

ITEM NO.	QTY.	PART NO.	DESCRIPTION
1	2	7000-2110J-15.1	15' CHANEL
2	2	7000-2110J-10.3	CHANNEL, (C7 X 9.8 X 115-5/16" LG)
3	4	7000-2110J-10.5	CHANNEL, (C7 X 9.8 X 115-5/16" LG)
4	12	7000-2110J-15.3	C7 CHANNEL BRACKET
5	6	7000-2110J-1	INNER JACK SLEEVE WELDMENT
6	6	7000-2110J-2	3/4" ALL-THREAD/NUT WELDMENT
7	6	7000-2110J-3	JACK LEG BRACKET
8	6	4770G	WASHER, 3/4" NARROW, GALV
9	6	4670G-BULK	NUT, 3/4" HEX, A563 GALV
10	50	2199	GRATING CLIP (NOT SHOWN)
11	64	4467G-2	BOLT, 5/8" X 2" LG HEX, A325 GALV
12	64	4764G-BULK	5/8" GALV LOCK WASHER
13	64	4660G-BULK	5/8" GALV HEX NUT
14	6	7000-2110J-JP	JACKPAD WELDMENT (15.5" SQ)
15	6	4310G-612	3/8" DIA X 6-1/2" LG GALV ALL-THREAD
16	12	4620G-BULK	NUT, 3/8" HEX, GALV
17	6	4724G-BULK	3/8" LOCK WASHER, GALV
18	12	4423G-BULK	BOLT, 3/8" X 1" LG HEX, GALV
19	5	7000-2110J-G24-15	1" X 1/8" PLATFORM GRATING 2' X 15'

THE INFORMATION CONTAINED IN THIS DRAWING IS THE SOLE PROPERTY OF ALT. ANY REPRODUCTION IN PART OR WHOLE WITHOUT THE WRITTEN PERMISSION OF ALT IS PROHIBITED.  9/27/2018	CAD GENERATED DRAWING, DO NOT MANUALLY UPDATE		 800-950-7960 FAX 940-455-2817 www.altfabrication.com sales@altfabrication.com	122 Leesley Lane Argyle, Texas 76226
	APPROVALS	DATE		
	DRAWN SF	03/29/13	PLATFORM 10' X 15'	
	CHECKED DMR	04/02/13	DWG. NO.	2110J-1015
	ENGINEER		REV.	B
ISSUED		SCALE: NTS	DO NOT SCALE DRAWING	SHEET: 1 OF 3

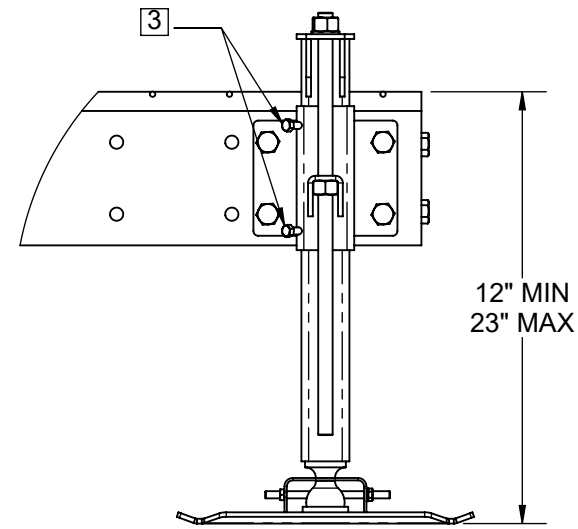
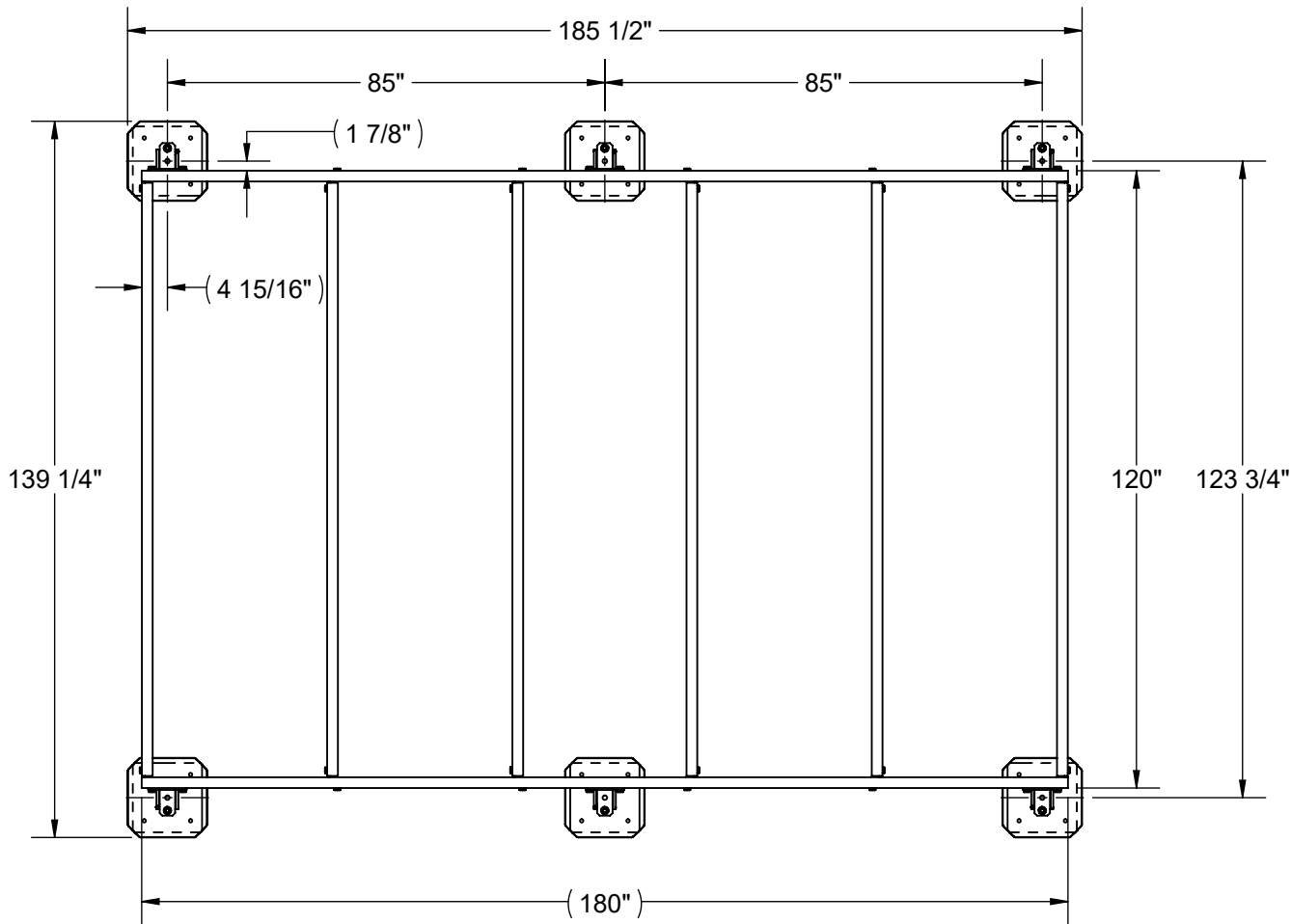

**DETAIL B**

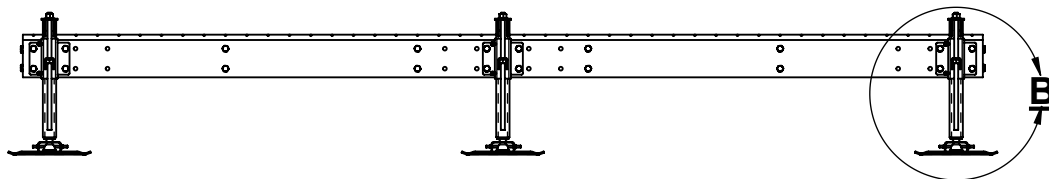

<p>THE INFORMATION CONTAINED IN THIS DRAWING IS THE SOLE PROPERTY OF ALT. ANY REPRODUCTION IN PART OR WHOLE WITHOUT THE WRITTEN PERMISSION OF ALT IS PROHIBITED.</p> <p>9/27/2018</p>	 <p>800-950-7960 FAX 940-455-2817 www.altfabrication.com sales@altfabrication.com</p>	<p>122 Leesley Lane Argyle, Texas 76226</p>			
		<p>TITLE: <b>PLATFORM 10' X 15'</b></p>			
	<p>FINISH: HDG</p>	<p>WEIGHT: 1200.88</p>	<p>SCALE: NTS</p>	<p>DO NOT SCALE DRAWING</p>	<p>SHEET: 2 OF 3</p>

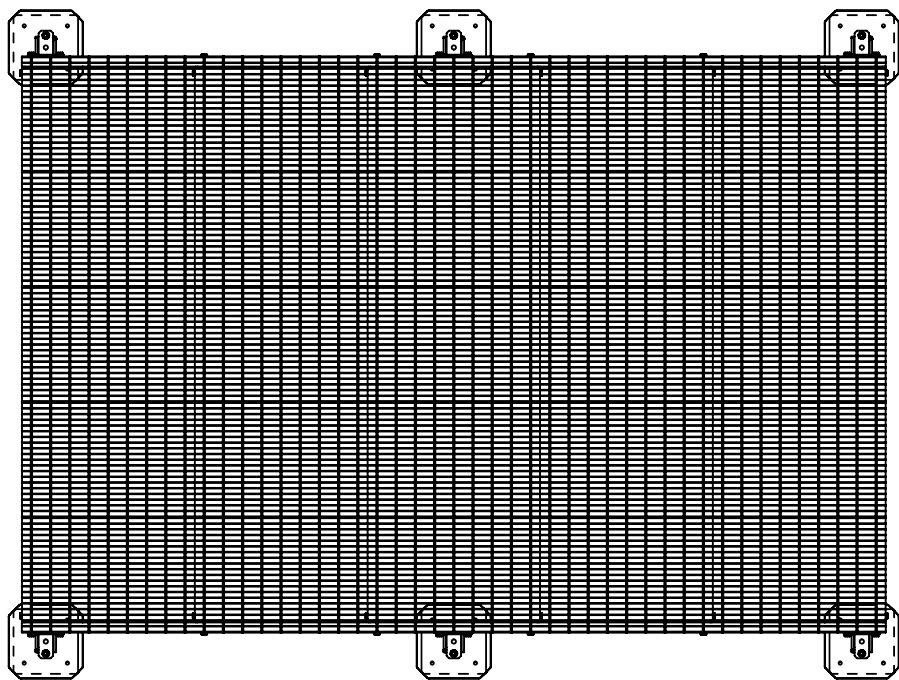
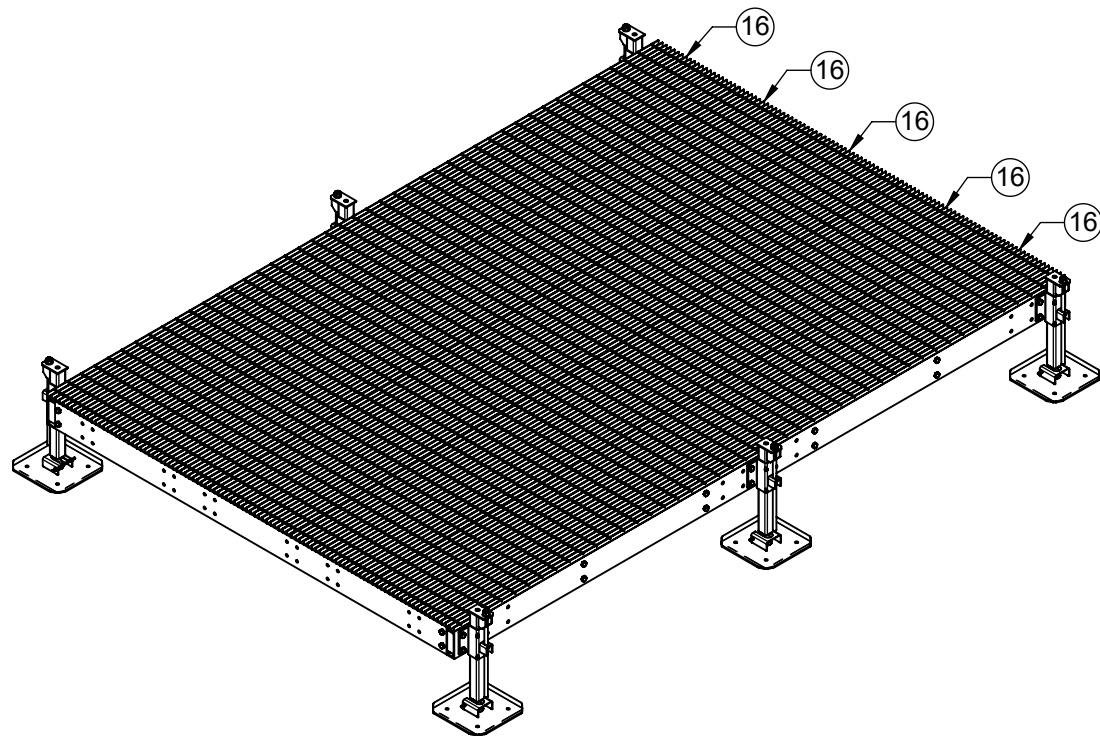

<p>THE INFORMATION CONTAINED IN THIS DRAWING IS THE SOLE PROPERTY OF ALT. ANY REPRODUCTION IN PART OR WHOLE WITHOUT THE WRITTEN PERMISSION OF ALT IS PROHIBITED.</p> <p>9/27/2018</p>	 <p>800-950-7960 FAX 940-455-2817 www.altfabrication.com sales@altfabrication.com</p>	<p>122 Leesley Lane Argyle, Texas 76226</p>			
		<p>TITLE: <b>PLATFORM</b> <b>10' X 15'</b></p>			
	<p>FINISH: HDG</p>	<p>WEIGHT: 1957.77</p>	<p>SCALE: NTS</p>	<p>DO NOT SCALE DRAWING</p>	<p>SHEET: 3 OF 3</p>