

DETAIL B

- 1. GRATING AND GRATING CLIPS OMITTED FOR CLARITY
- 2. LEG LENGTHS ARE ADJUSTED BY TURNING ITEM 6 NUT AFTER ITEM 9 NUT IS INSTALLED
- 3. INSTALL AND TIGHTEN ITEM 18 SET SCREWS AFTER FINAL LEG ADJUSTMENTS HAVE BEEN MADE.

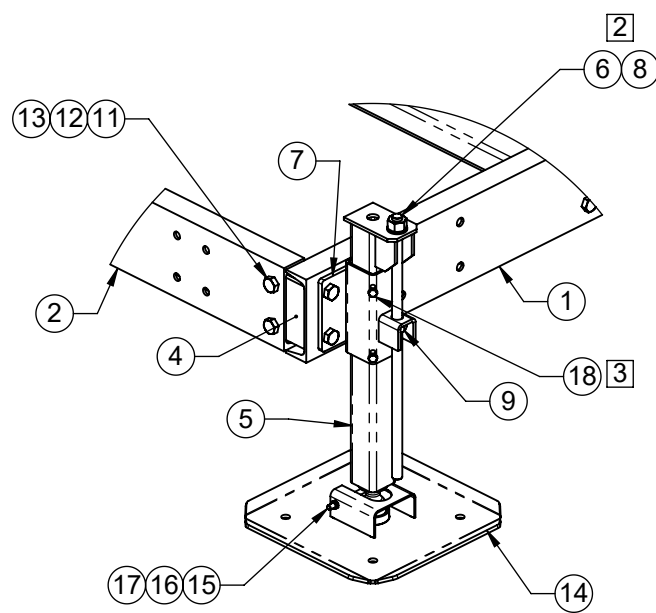

DETAIL A

ITEM NO.	QTY.	PART NO.	DESCRIPTION
1	2	7000-2110J-10.1	C7 SIDE CHANNEL
2	2	7000-2110J-10.3	CHANNEL, (C7 X 9.8 X 115-5/16" LG)
3	3	7000-2110J-10.5	CHANNEL, (C7 X 9.8 X 115-5/16" LG)
4	10	7000-2110J-15.3	C7 CHANNEL BRACKET
5	6	7000-2110J-1	INNER JACK SLEEVE WELDMENT
6	6	7000-2110J-2	3/4" ALL-THREAD/NUT WELDMENT
7	6	7000-2110J-3	JACK LEG BRACKET
8	6	4770G	WASHER, 3/4" NARROW, GALV
9	6	4670G-BULK	NUT, 3/4" HEX, A563 GALV
10	60	2199	GRATING CLIP (NOT SHOWN)
11	52	4467G-2	BOLT, 5/8" X 2" LG HEX, A325 GALV
12	52	4660G-BULK	5/8" GALV HEX NUT
13	52	4764G-BULK	5/8" GALV LOCK WASHER
14	6	7000-2110J-JP	JACKPAD WELDMENT (15.5" SQ)
15	6	4310G-612	3/8" DIA X 6-1/2" LG GALV ALL-THREAD
16	12	4620G-BULK	NUT, 3/8" HEX, GALV
17	6	4724G-BULK	3/8" LOCK WASHER, GALV
18	12	4423G-BULK	BOLT, 3/8" X 1" LG HEX, GALV
19	5	7000-2110J-G24-120	1" X 1/8" PLATFORM GRATING 24" X 120"

THE INFORMATION CONTAINED IN THIS DRAWING IS THE SOLE PROPERTY OF ALT. ANY REPRODUCTION IN PART OR WHOLE WITHOUT THE WRITTEN PERMISSION OF ALT IS PROHIBITED.

10/29/2018

FINISH: HDG WEIGHT: 1457.4

CAD GENERATED DRAWING, DO NOT MANUALLY UPDATE



800-950-7960
FAX 940-455-2817
www.altfabrication.com
sales@altfabrication.com

122 Leesley Lane
Argyle, Texas
76226

APPROVALS	DATE
DRAWN SF	06/25/10
CHECKED CH	06/25/10
ENGINEER	
ISSUED	

TITLE:	REV.
PLATFORM	B
10' X 10'	
DWG. NO.	
2110J-1010	
SCALE: NTS	DO NOT SCALE DRAWING
SHEET: 1 OF 2	

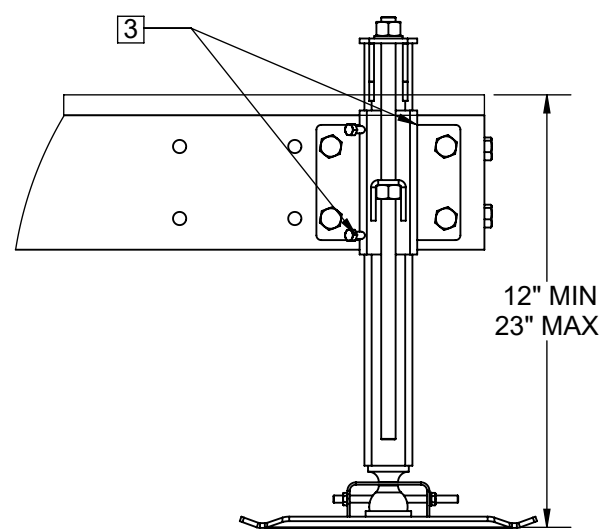
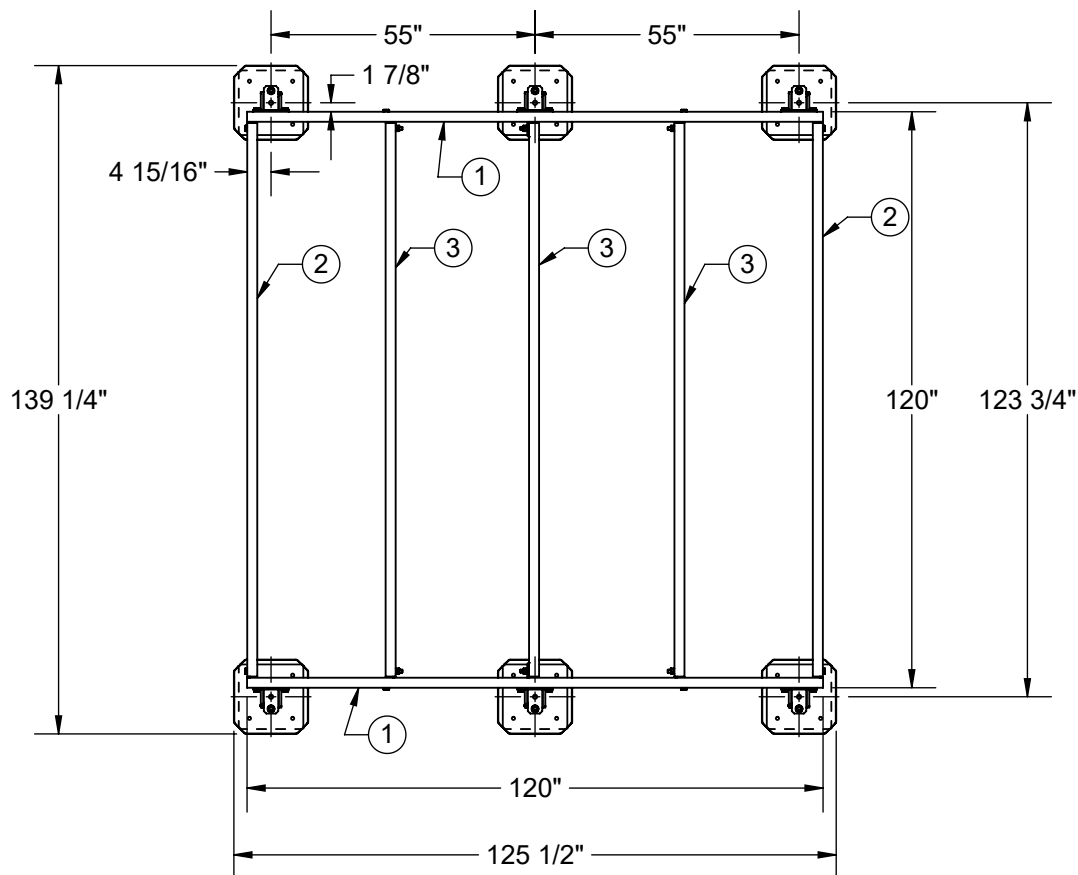

DETAIL C

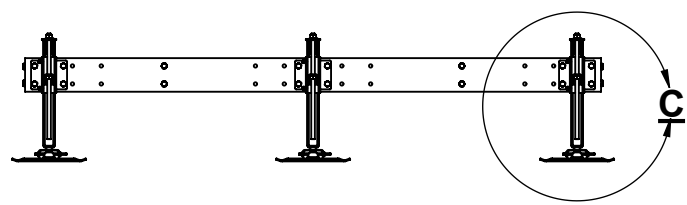

THE INFORMATION CONTAINED IN THIS DRAWING IS THE SOLE PROPERTY OF ALT. ANY REPRODUCTION IN PART OR WHOLE WITHOUT THE WRITTEN PERMISSION OF ALT IS PROHIBITED. 10/29/2018	CAD GENERATED DRAWING, DO NOT MANUALLY UPDATE		 800-950-7960 FAX 940-455-2817 www.altfabrication.com sales@altfabrication.com	122 Leesley Lane Argyle, Texas 76226		
	APPROVALS	DATE		TITLE:		
	DRAWN SF	06/25/10	PLATFORM			
	CHECKED CH	06/25/10	10' X 10'			
	ENGINEER		DWG. NO.			REV.
		2110J-1010			B	
FINISH: HDG	WEIGHT: 1457.4	ISSUED	SCALE: NTS	DO NOT SCALE DRAWING	SHEET: 2 OF 2	