



# #2109-3 Two Pole Equipment Rack

## Assembly Instructions

BEFORE ASSEMBLY, review the detailed diagram to familiarize yourself with each part.

### Step-by-Step Instructions for assembling Equipment Rack

1. Set poles in concrete per contractors specifications. See "A"
2. Attach channel strut to the 3-1/2" O.D. poles using the clamps provided. See diagram "B". Channel slides onto the clamp.
3. Tighten bolts and screw on clamp.
4. Space Channel strut per contractor's specifications for equipment.

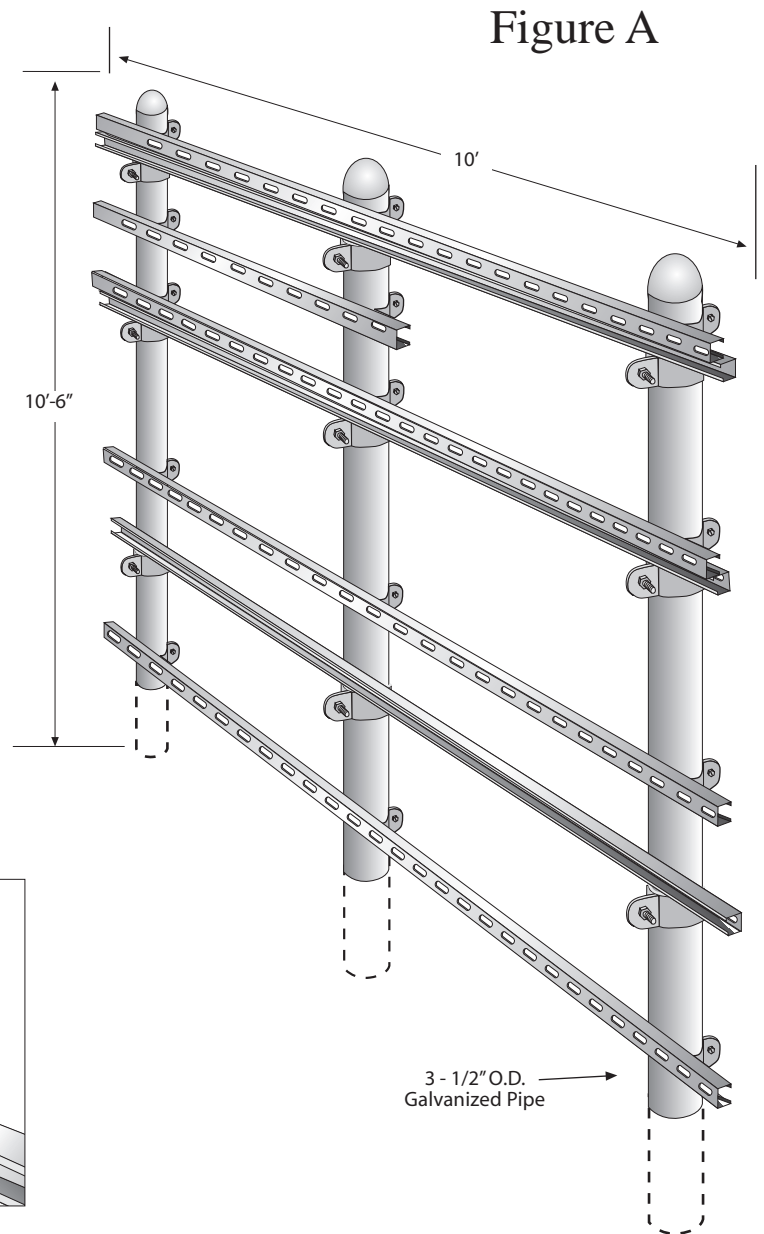

Figure A

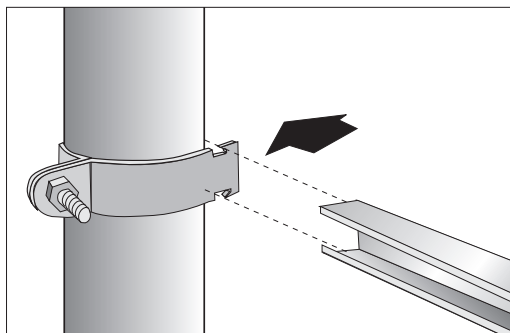

Figure B

## #2109-3 Two Pole Equipment Rack Assembly Instructions

Rev. 2/25/00

**Series 2100 • Tower Components**

Tower Components • Lightning Protection • Grounding Components  
Transient Voltage Surge Suppression